

**LUMINAIRE:**  
 UCM-SR-STR-H2-FTG (UNIVERSE COLLECTION SERIES BY ARCHITECTURAL AREA LIGHTING) WITH ONE-PIECE BALLAST DIE CAST ALUMINUM HOUSING, SPUN ALUMINUM 24" HOOD WITH RINGS AND FLAT GLASS LENS.

**COLOR:** DGN (DARK GREEN)  
**VOLTAGE:** 240V

**LAMP:** 100W MH (BY PHILLIPS, PART #MHC100/U/M/3K/CLEAR)

**LAMP:** SEE STANDARD DETAIL LGT 074R FOR RESIDENTIAL STREET LIGHTS.  
**OPTICS:** TYPE II (H2), SHORT, FULL-CUTOFF

**LUMINAIRE ARM:**

SLA17-DGN-PCR (UNIVERSE COLLECTION SERIES BY ARCHITECTURAL AREA LIGHTING) WITH STAINLESS STEEL FASTENERS AND PHOTOCELL.

**COLOR:** DGN (DARK GREEN)

**PHOTOCELL:** FISHER-PIERCE, PART #7760-SSS (OR EQUAL)

**POLE:**

PR4-4R16-125 (4" DIA. ROUND SMOOTH STRAIGHT ALUMINUM SHAFT (BY ARCHITECTURAL AREA LIGHTING).

**COLOR:** DGN (DARK GREEN)

**BASE COVER:**

CYCLONE DECORATIVE BASE, PART # BD55. COLOR TO MATCH POLE.

**BASE PLATE:**

BASE PLATE COMES WITH 4 ANCHOR BOLTS AND 8 NUTS AND WASHERS. BOLTS PROJECTION (ABOVE FOUNDATION) SHALL NOT EXCEED 3-1/2".

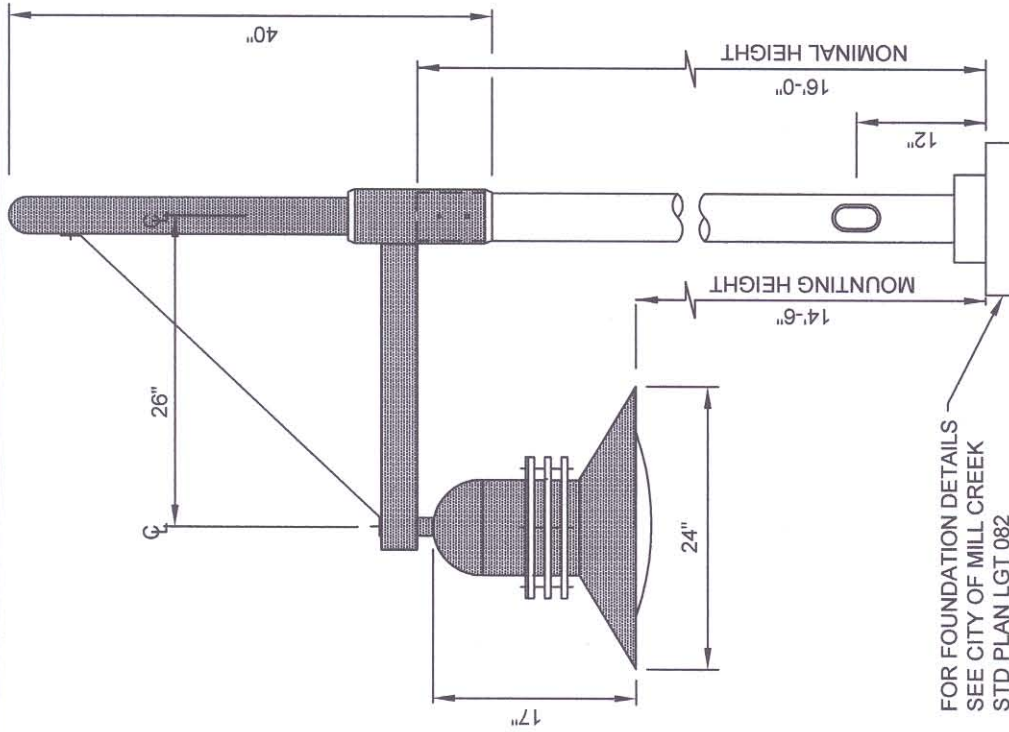
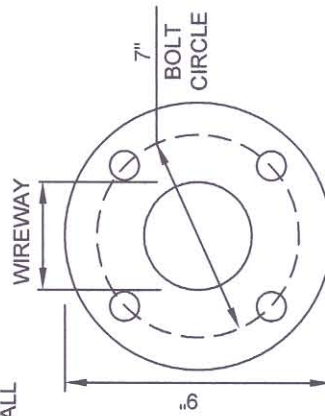

**NOTES:**

1. THIS STANDARD SHALL APPLY TO COMMERCIAL TOWN CENTER & MAIN ST STREET LIGHTS INSTALLED ALONG THE WEST SIDE OF SR 527 (BOTHELL-EVERETT HWY), NORTH OF 164TH STREET SE, OR AS REQUESTED BY THE CITY OF MILL CREEK.
2. INSTALLATION OF ALL LUMINAIRE AND POLE COMPONENTS SHALL COMPLY WITH MANUFACTURER'S RECOMMENDATIONS.
3. METAL HALIDE LAMP BULBS AND ALL NECESSARY PARTS FOR METAL HALIDE FIXTURES, SHALL BE USED WITH THIS LIGHT ON MAIN STREET, FROM 250' NORTH OF 151ST ST. SE TO MILL CREEK BLVD. ON THE SOUTH.

 <p>DEPARTMENT OF PUBLIC WORKS</p>	<p><b>STANDARD PLAN</b></p>	<p><b>LGT 074C</b></p>
	<p><b>TOWN CENTER &amp; MAIN ST. COMMERCIAL STREET LIGHT</b></p>	
<p>APPROVED: <i>Douglas Jefferson</i>                  Director of Public Works/City Engineer</p>		
<p>REVISION: MAY 2005</p>	<p>NOT TO SCALE</p>	<p>BY: JC</p>